

# MotorGuide® REPAIR PARTS

**Model:**  
**HVT3200**

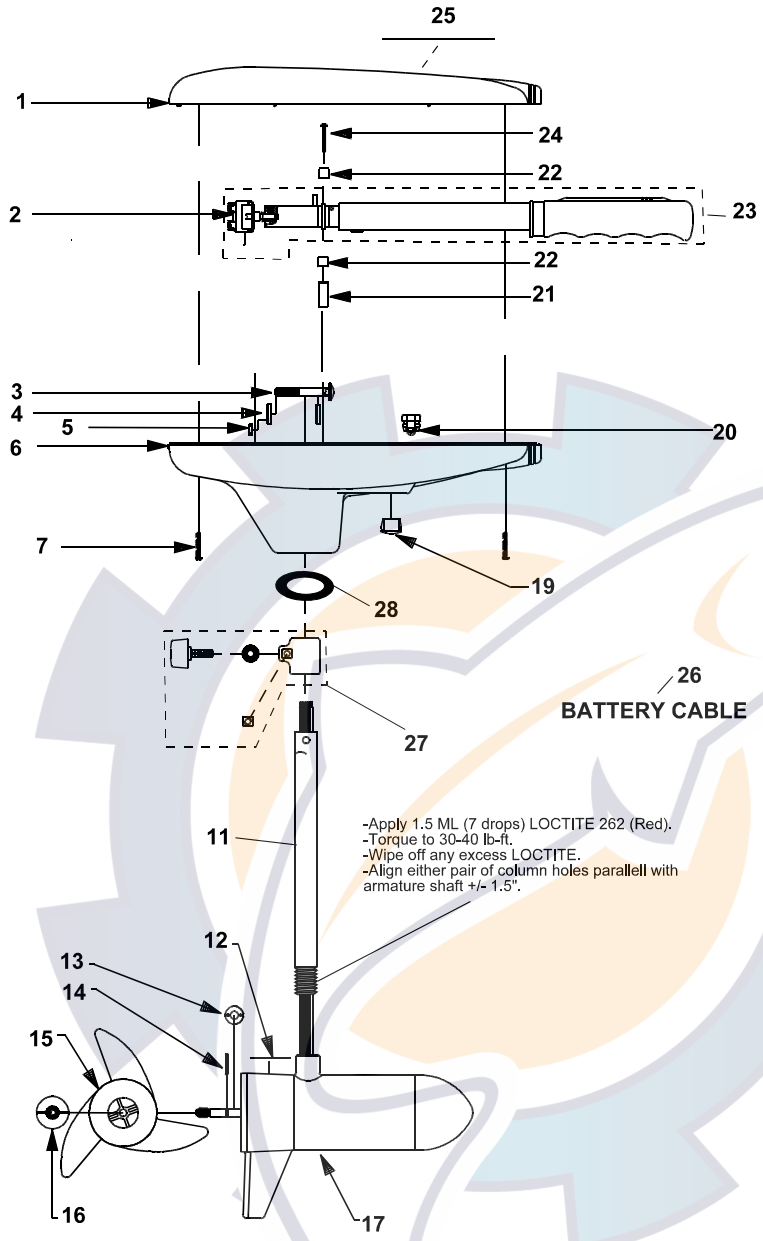

**SPECIFICATIONS:**

Year of Intro	2000
Thrust	32LBS
Volts	12VDC
Amp Draw	0 to 48 amps
Mount	31 Transom
Speeds	5/2

**PARTS ORDERING & TECH ASSISTANCE**

MotorGuide Consumer Relations  
Phone 918-831-6989  
Fax 800-982-8093

*Returned Goods must be accompanied with a Returned Goods Authorization. Contact MotorGuide Consumer Relations to obtain RGA.*

-Apply 1.5 ML (7 drops) LOCTITE 262 (Red).  
-Torque to 30-40 lb-ft.  
-Wipe off any excess LOCTITE.  
-Align either pair of column holes parallel with armature shaft +/- 1.5".

KEY	DESCRIPTION	PART #	KEY	DESCRIPTION	PART #
1	COVER BLACK	AT053-10	15	PROP/ 3 BLADE	AF124-10
2	ROTARY SWITCH	KT150-02	16	PROP NUT	AR099-01
3	BOLT	TT134-01	17	MOTOR	HF397-04
4	CURVED WASHER	TT171-04	18	DEPTH ADJUSTMENT COLLAR	AR051-01
5	NYLON LOCK NUT	XT098-02	19	1/2" HOLE PLUG	FP021-03
6	T/H BASE BLACK	AR004-14	20	GROMMET	GR019-03
7	SCREW #8 X 1"	LF141-04	21	WIRE BRACKET	AT155-04
8	BAR KNOB	AR082-02	22	RETAINER CLAMP	AR036-01
9	CLAMP WASHER	AR171-01	23	5 SPEED HANDLE ASY 96-97	BT372-06
10	SUPPORT NUT	FR098-01	24	8 X 1-3/8 SCREW	AR133-01
11	42" .095 SS H/O COLUMN	FR049-15	25	NOMENCLATURE	
12	MARINE LOWER UNIT DECAL	AF060-04	26	BATTERY CABLE	TT328-03
13	MONOFILAMENT WASHER	AR175-01	27	DEPTH COLLAR ASY	AR158-01
14	PROP DRIVE PIN	BR102-01	28	COLUMN SEAL	AT079-01

**Model:**  
**HVT3200**

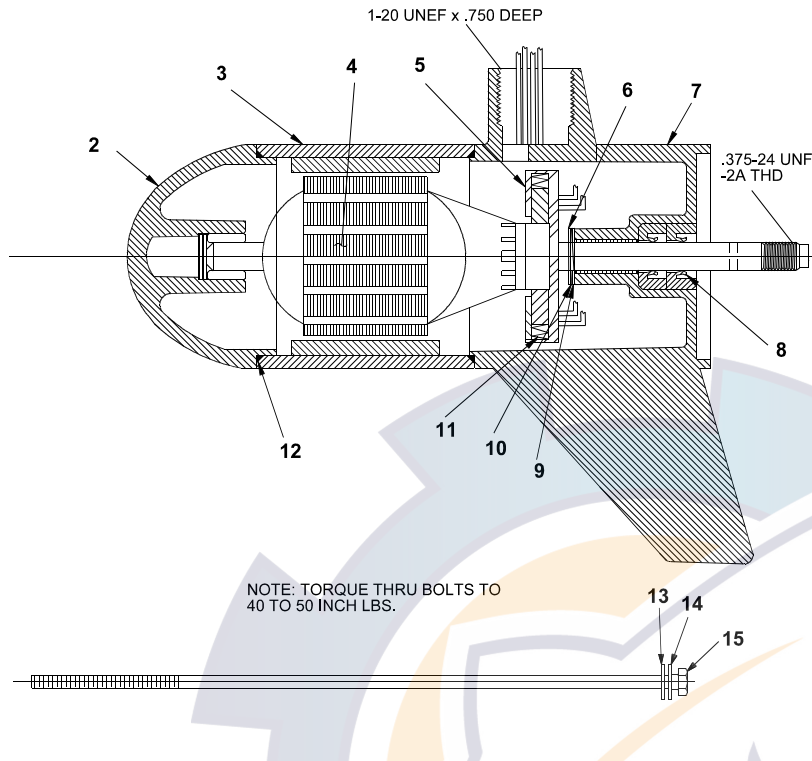

KEY	QTY	DESCRIPTION	PART NO.
1	X	MOTOR	HF397-04
2	1	NOSE CAP	FF3212-01
3	1	HOUSING ASY	HF3210-01
4	1	ARMATURE 3"	HF3207-02
5	1	BRUSH ASY LESS SPRING	FF3201-01
6	1	E RING	MR219-02
7	1	COMM CAP	FF3205-01
8	2	SHAFT SEAL	MR223-01
9	1	NYLATRON WASHER	MR226-01
10	1	WASHER	MR227-01
11	2	BRUSH SPRINGS	MR214-02
12	2	O RING SEAL	HF217-01
13	4	STATIC SEAL	MR222-01
14	4	THRU BOLT WASHER	MR216-01
15	2	THRU BOLT	MR218-06

**WIRING**

